

CLEAN & COOL ENVIRONMENT

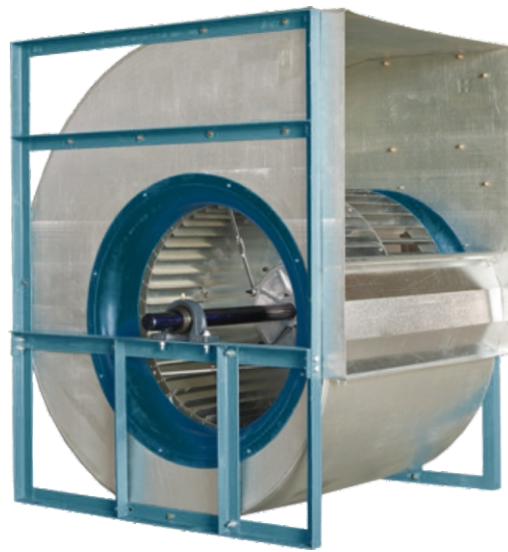

Centrifugal Blower-(FC)

VENTCOOL SYSTEMS (P) LTD.

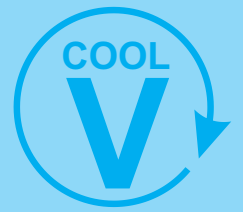

CLEAN & COOL ENVIRONMENT



Double Inlet Forward Curved Centrifugal Blower

The VIFC series Centrifugal Blower (Forward Curved) consist of Double Inlet Double Width (DIDW) centrifugal fans. These fans have forward curved impellers with forward curved blades having special profile to give you maximum efficiency at low noise levels. These impellers are statically and dynamically balanced. The fans are suitable for various applications, where high volume air displacement is required like Air Cooling, General Ventilation, Pressurization etc., in commercial process and industrial HVAC systems

The VIFC series is available in type A where strong side frame (M.S.) in welded construction are provided to support the Bearing and for wheel assembly

Fan size : 500 to 1120

Volume : 1000 to 100000 m³/h

Total Pressure : 100Pa to 1600 Pa



CLEAN & COOL ENVIRONMENT

TYPE - A

MODEL VIFC-D (500 - 1120)

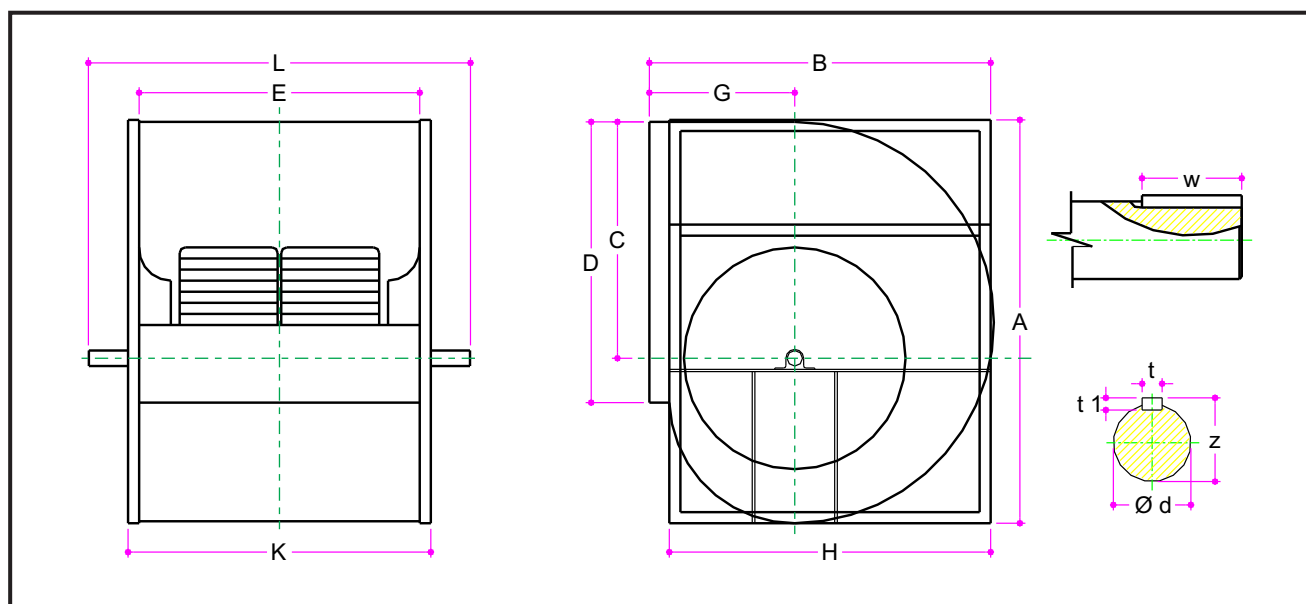

FAN Dia	A	B	C	D	E	G	H	K	L	t	t1	w	z	Ød
500	921	802	538	638	638	352	752	718	960	12	8	70	43	40
560	1033	894	603	714	714	390	846	814	1050	12	8	90	43	40
630	1160	1000	679	800	800	434	947	900	1170	14	9	90	48.5	45
710	1305	1122	765	898	898	484	1059	998	1285	14	9	90	54	50
800	1471	1256	862	1006	1006	540	1182	1106	1390	18	11	90	64	50
900	1651	1410	971	1130	1130	604	1321	1230	1570	18	11	90	64	60
1000	1813	1542	1066	1266	1266	656	1452	1366	1725	18	11	90	64	60
1120	2038	1727	1200	1422	1422	748	1632	1542	1900	22	14	110	80	75



CLEAN & COOL ENVIRONMENT

PRODUCT RANGE

- Dust Proofing
- Dust Scrubbers
- Combustion Fans
- Dust Collector
- Roof Extractor
- Paint Booths
- Bag Filters
- Axial Fans
- Centrifugal Blowers
- General Ventilation
- Fume/Dust Extractor System
- Air Cooling System
- Humidifier
- Cellulose Pad

The intention of this brochure is to introduce you to, and acquaint you with the capabilities of the Ventcool organization in the offered product areas. It will not answer all your immediate questions, and indeed, it will no doubt raise others. We welcome your interest in our products and shall be very pleased to provide further information.

GUARANTEE

Ventcool guarantees its products to be free of defects in materials and workmanship for a period of one year from the date of delivery from the factory, provided motors are properly installed with overload protector. Ventcool agrees to repair or replace defective parts or part to be returned to the factory, all transportation charges prepaid. Ventcool does not guarantee against abrasion, corrosion or erosion. Ventcool shall not be held responsible for any charges in connection with the removal or replacement of alleged defective equipment nor for incidental consequential damages.

In accordance with our policy of continual improvement in design, we reserve the right to depart from the details given in this brochure.

VENTCOOL SYSTEMS (P) LTD.

33/6, DLF INDUSTRIAL AREA, PHASE - I, 14TH MILE STONE, MATHURA ROAD, FARIDABAD - 121003, HARYANA (INDIA)
Ph. 0129-4109776, Mob. 9818046048, 9582341559

Email. ventcoolsystems@gmail.com, Web. www.ventcoolsystems.com