

CLEAN & COOL ENVIRONMENT

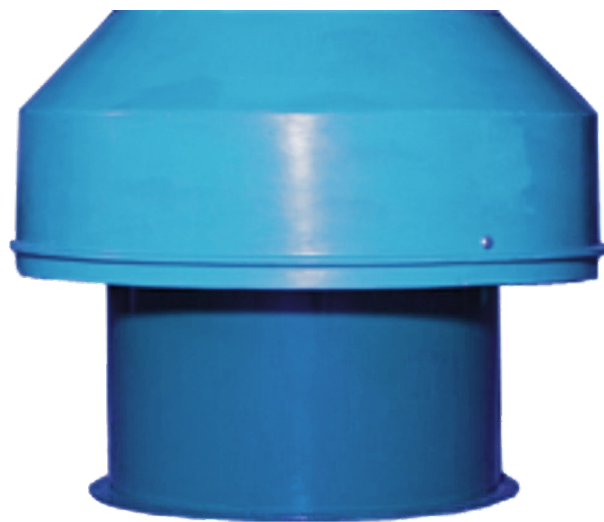

Roof Extractor

VENTCOOL SYSTEMS (P) LTD.

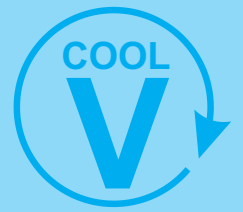

CLEAN & COOL ENVIRONMENT

The Roof Extractor is a motor driven fan unit having cast aluminum alloy impeller, aerofoil section blades and is provided with durable weather proof exhaust cowl.

This is ideal for extraction of air supply through the roof, usually preferable in factories, power plant, steel plant and foundries.

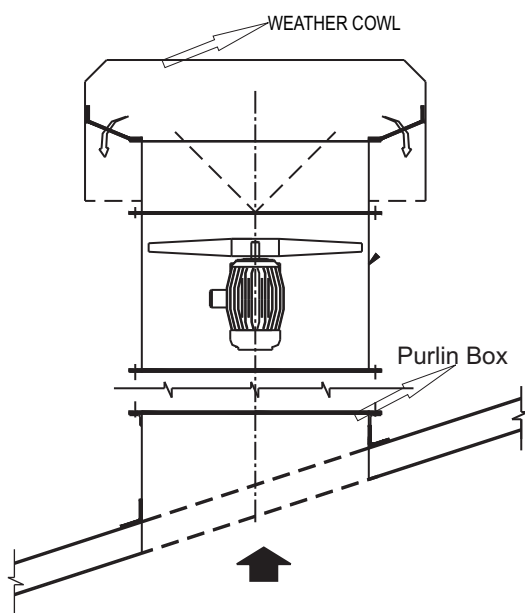
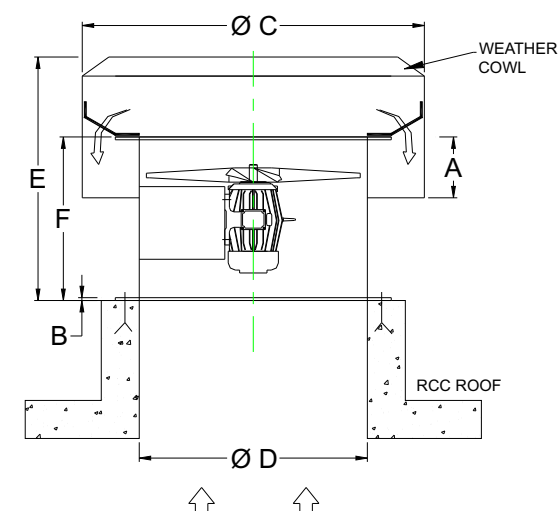

Fig.: Exploded View

DISCERNIBLE FEATURES

Fan Size: 500 to 1200 mm
Flow rates up to 100000 cmh
Pressures up to 600Pa

ROOF EXTRACTOR

ACRE	A	B	ØC	ØD	E	F
50	160	6	750	500	540	350
60	160	6	900	600	640	430
70	200	6	1050	700	746	440
80	210	6	1200	800	846	560
90	210	6	1350	900	950	575
100	225	6	1500	1000	1046	590
120	290	6	1800	1200	1265	680
140	300	8	2100	1400	1410	760
160	325	8	2400	1600	1525	800

APPLICATION

Finds application in extraction of air supply through roofs/ridges in industrial building, factories, power plants, steel plants, foundries etc.



CLEAN & COOL ENVIRONMENT

This fan is mostly placed to exhaust or supply the air of corrosive nature of hazardous for the motor. In this the motor is not in the stream of air, this remain protected from the particles available in the air.

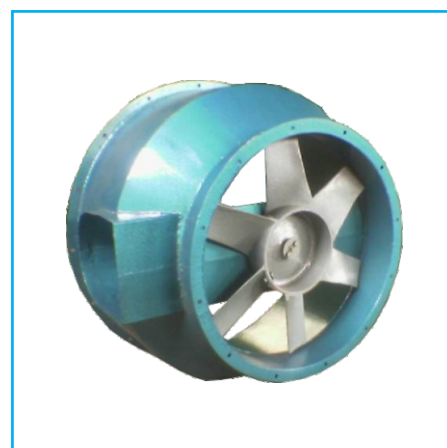

BIFURCATED FAN

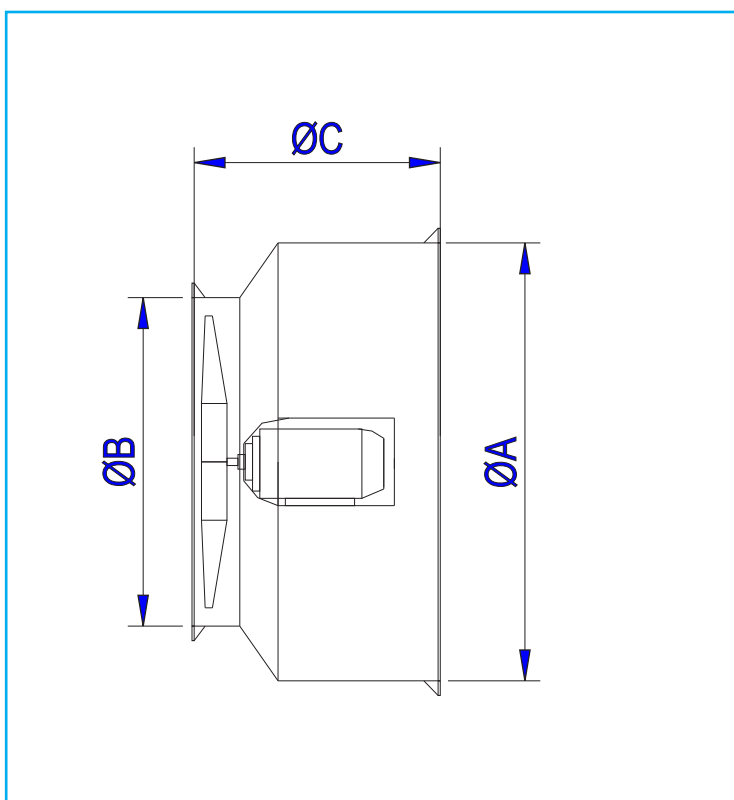

SIZE	A	B	C
50	700	500	800
60	850	600	900
70	950	700	1000
80	1080	800	1050
90	1250	900	1200
100	1350	1000	1250
120	1550	1200	1600



CLEAN & COOL ENVIRONMENT

PRODUCT RANGE

- Dust Proofing
- Dust Scrubbers
- Combustion Fans
- Dust Collector
- Roof Extractor
- Paint Booths
- Bag Filters
- Axial Fans
- Centrifugal Blowers
- General Ventilation
- Fume/Dust Extractor System
- Air Cooling System
- Humidifier
- Cellulose Pad

The intention of this brochure is to introduce you to, and acquaint you with the capabilities of the Ventcool organization in the offered product areas. It will not answer all your immediate questions, and indeed, it will no doubt raise others. We welcome your interest in our products and shall be very pleased to provide further information.

GUARANTEE

Ventcool guarantees its products to be free of defects in materials and workmanship for a period of one year from the date of delivery from the factory, provided motors are properly installed with overload protector. Ventcool agrees to repair or replace defective parts or part to be returned to the factory, all transportation charges prepaid. Ventcool does not guarantee against abrasion, corrosion or erosion. Ventcool shall not be held responsible for any charges in connection with the removal or replacement of alleged defective equipment nor for incidental consequential damages.

In accordance with our policy of continual improvement in design, we reserve the right to depart from the details given in this brochure.

VENTCOOL SYSTEMS (P) LTD.

33/6, DLF INDUSTRIAL AREA, PHASE - I, 14TH MILE STONE, MATHURA ROAD, FARIDABAD - 121003, HARYANA (INDIA)
Ph. 0129-4109776, Mob. 9818046048, 9582341559

Email. ventcoolsystems@gmail.com, Web. www.ventcoolsystems.com